



Tirelessly innovative in sheet transport.

-confidential-

Fragebogen für Rollenschneider Questionnaire for Reel Sheeter

Bitte zutreffendes ausfüllen oder ankreuzen
Please fill in or mark accordingly

Firma/company

Name/name

Datum/date

Bestimmungsland/country of destination

Fragebogen für Rollenschneider - Questionnaire for Reel Sheeter

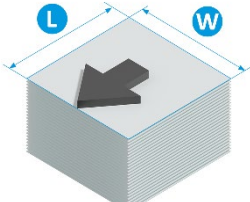
Hersteller (Druck-)Maschine manufacturer (press/) machine		
Maschinen-Typ machine type		
Maschinen-Nummer machine serial number		
Baujahr year of manufacture		
Neue (Druck-)Maschine new (press/) machine	<input type="checkbox"/>	oder or	Nachrüstung retrofit <input type="checkbox"/>
Einlaufhöhe infeed height mm		
Bogenformat (WxL) sheet size (WxL)	min. Breite W sheet width W mm	Länge L sheet length L mm	
	max. Breite W sheet width W mm	Länge L sheet length L mm	
Material substrate	<input type="checkbox"/> Papier <i>paper</i> Gewicht (g/m²) <i>weight (gsm)</i> (min. – max.) Dicke (mm) <i>thickness (mm)</i> (min. – max.) <hr/> <input type="checkbox"/> Folie (Antistatik notwendig) <i>foil, plastics</i> (Antistatic necessary) Gewicht (g/m²) <i>weight (gsm)</i> (min. – max.) Dicke (µm) <i>thickness (µm)</i> (min. – max.)		

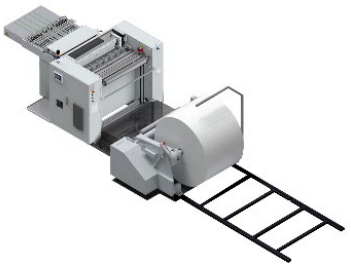
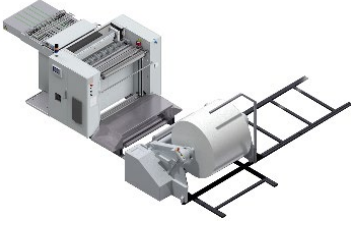
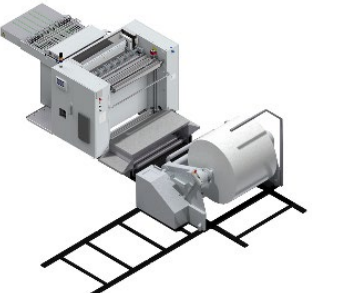
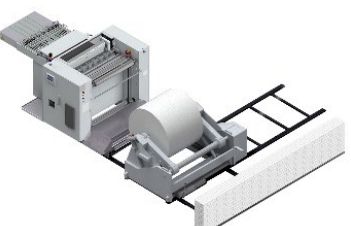
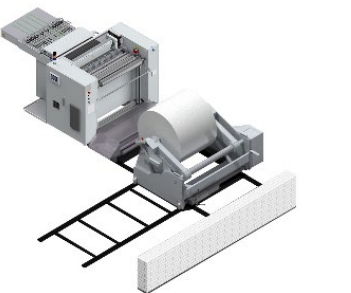
<p>Stellvariante configuration</p>	<p><input type="checkbox"/> I</p> <p>Inline, Parken in Linie zur Druckmaschine, Rollenbeladung in Bogenlaufrichtung <i>Inline, parking inline with press, reel loading in sheet run direction</i></p>	
	<p><input type="checkbox"/> AI</p> <p>Parkposition der Abrollung auf Antriebsseite, Rollenbeladung in Bogenlaufrichtung <i>parking position of the unroller on drive side, reel loading in sheet run direction</i></p>	
	<p><input type="checkbox"/> BI</p> <p>Parkposition der Abrollung auf Bedienseite, Rollenbeladung in Bogenlaufrichtung <i>parking position of the unroller on operation side, reel loading in sheet run direction</i></p>	
<p>Für eingeschränkte Platzgegebenheiten for limited space conditions</p>	<p><input type="checkbox"/> AG</p> <p>Parkposition der Abrollung auf Antriebsseite, Rollenbeladung entgegen Bogenlaufrichtung <i>parking position of the unroller on drive side, reel loading opposite to sheet run direction</i></p>	
	<p><input type="checkbox"/> BG</p> <p>Parkposition der Abrollung auf Bedienseite, Rollenbeladung entgegen Bogenlaufrichtung <i>parking position of the unroller on operation side, reel loading opposite to sheet run direction</i></p>	

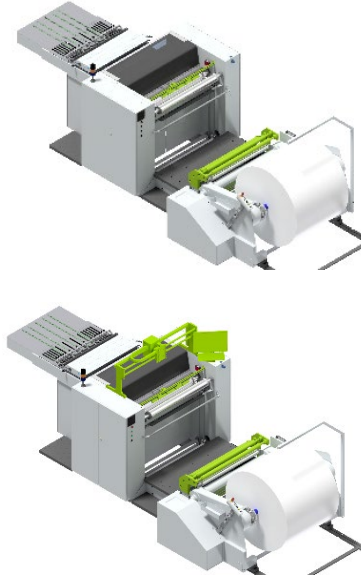
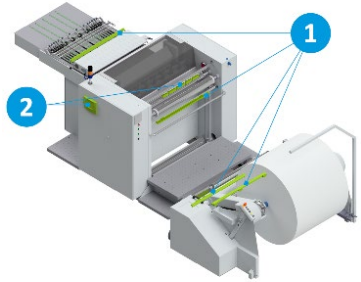
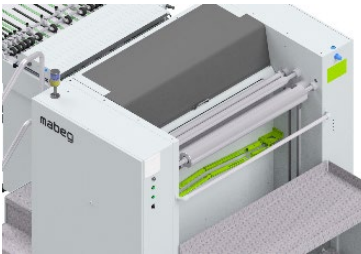
<p>Optionen</p>	<p><input type="checkbox"/> Register-Schnitt mittels Sensors / RegisterCut using sensors</p> <p>Erkennung der Schnittmarke mittels Schnittmarkensensor detection of cut-mark by means of cut-mark sensor</p> <hr/> <p><input type="checkbox"/> Register-Schnitt mittels Kamera / RegisterCut using a camera system</p> <p>Kamerasystem zur Erkennung der Schnittposition camera system for detection of cutting position</p>	
	<p>Entladung (Antistatikeinrichtung) / Anti-static equipment zum Entladen statisch aufgeladener Materialien for discharging statically charged materials</p> <p><input type="checkbox"/> Ausführung 1: SIMCO ohne Manager / version 1: SIMCO <u>without</u> manager</p> <p><input type="checkbox"/> Ausführung 1 + 2: SIMCO mit Manager* / version 1 + 2: SIMCO <u>with</u> manager*</p> <p><i>*Note: SIMCO with manager without UL approval.</i></p>	
	<p><input type="checkbox"/> Befeuchtung / Humidification</p> <p>zur Nachbefeuchtung des zu verarbeitenden Materials bei geringer Materialfeuchte für weitere Verarbeitungsprozesse. for remoistening the material being processed if the material humidity is too low for further processing.</p>	

Fragebogen für Rollenschneider - Questionnaire for Reel Sheeter

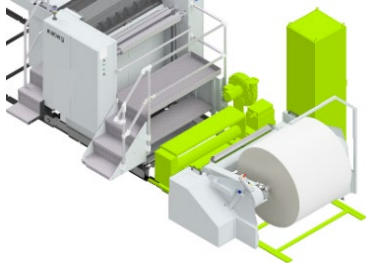
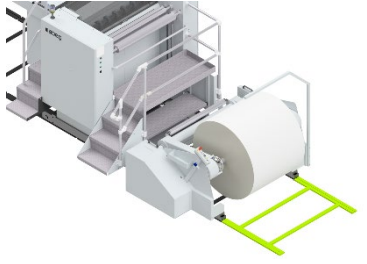
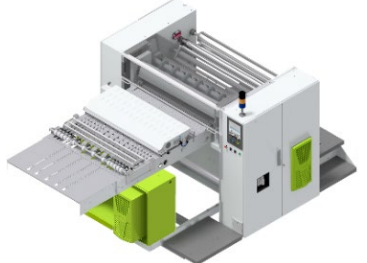
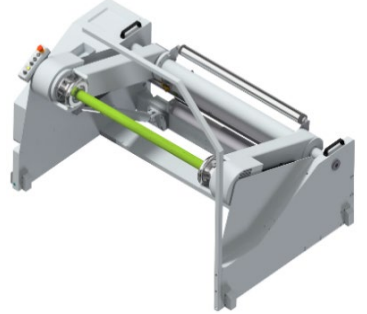
<p>KORONA-Anlage / CORONA unit zur Folienverarbeitung for foil/IML processing</p> <p><input type="checkbox"/> Einseitig / single-sided</p> <p><input type="checkbox"/> Zweiseitig / double-sided</p>	
<p><input type="checkbox"/> Vorbereitung für späteren Anbau einer KORONA-Anlage preparation for retrofit of CORONA unit</p>	
<p><input type="checkbox"/> Schaltschrank-Kühlgerät / control cabinet cooling unit</p> <p>bei Umgebungstemperaturen ab 35° C (ab 95° F) for surrounding temperatures above 35° C (above 95° F)</p>	
<p>Pneumatik-Spannwellen (1 Set = 2 Stück) / pneumatic expansion shafts (1 set = 2 pcs)</p> <p><input type="checkbox"/> Ø 3" / 76 mm</p> <p><input type="checkbox"/> Ø 6" / 152 mm</p> <p><input type="checkbox"/> andere</p> <p>others " / mm</p>	

Sonstige Angaben und Wünsche:
further details and requests:

.....

.....

.....

Unterschrift
signature

More than 75 years MABEG

MABEG has been focusing on Sheet Handling and Reel Sheeting for over 75 years.

We like to compare ourselves with the leaf-cutting ant. Like us, it has specialized in the persistent cutting and transporting of leaves.

We started with Sheet Feeders and Reel Sheeters. Over the years, we have continuously developed, and we have updated, improved and expanded our product portfolio.

Our three cubes show what this includes: **machines**, **components** and **service**.



The **grey cube** reflects our machines. This includes our Sheet Feeders (MSF), our Sheet Stackers (MST), our Modular Sheet Processors or Modular Sheet Inspection Lines (MSP) as well as our Reel Sheeters (RS).

Our components are found in the **blue cube**. This includes our Suction Heads and Sheet Alignment, such as our Side Lays. So, our Suction Heads are the heart of our Sheet Feeders and the precise Sheet Alignment is the basis for the further transport of a sheet.

The **green cube** covers the complete service range. This includes, for example, the installation and maintenance of the machines or the spare and wear parts.

We are proud of our core competence: Sheet Handling. Our years of experience, our unique know-how and our competent team make us a reliable specialist provider.



Would you like to learn more about us?

Then feel free to visit our website or our social media channels.

